

EQUINOX

Blitzer Impact 384 Strobe



Order codes: EQLED425

WARNING

FOR YOUR OWN SAFETY, PLEASE READ THIS USER MANUAL CAREFULLY BEFORE YOUR INITIAL START-UP!

- Before your initial start-up, please make sure that there is no damage caused during transportation.
- Should there be any damage, consult your dealer and do not use the equipment.
- To maintain the equipment in good working condition and to ensure safe operation, it is necessary for the user to follow the safety instructions and warning notes written in this manual.
- Please note that damages caused by user modifications to this equipment are not subject to warranty.



IMPORTANT:

The manufacturer will not accept liability for any resulting damages caused by the non-observance of this manual or any unauthorised modification to the equipment.

- Never let the power cable come into contact with other cables. Handle the power cable and all mains voltage connections with particular caution!
- Never remove warning or informative labels from the unit.
- Do not open the equipment and do not modify the unit.
- Do not connect this equipment to a dimmer pack.
- Do not switch the equipment on and off in short intervals, as this will reduce the system's life.
- Only use the equipment indoors.
- Do not expose to flammable sources, liquids or gases.
- Always disconnect the power from the mains when equipment is not in use or before cleaning! Only handle the power-cable by the plug. Never pull out the plug by pulling the power-cable.
- Make sure that the available mains supply voltage is between 100~240V AC, 50/60Hz.
- Make sure that the power cable is never crimped or damaged. Check the equipment and the power cable periodically.
- If the equipment is dropped or damaged, disconnect the mains power supply immediately and have a qualified engineer inspect the equipment before operating again.
- If the equipment has been exposed to drastic temperature fluctuation (e.g. after transportation), do not connect power or switch it on immediately. The arising condensation might damage the equipment. Leave the equipment switched off until it has reached room temperature.
- If your product fails to function correctly, stop use immediately. Pack the unit securely (preferably in the original packing material), and return it to your Pro Light dealer for service.
- Only use fuses of same type and rating.
- Repairs, servicing and power connection must only be carried out by a qualified technician. THIS UNIT CONTAINS NO USER SERVICEABLE PARTS.
- This lighting fixture is for professional use only - it is not designed for or suitable for household use. The product must be installed by a qualified technician in accordance with local territory regulations. The safety of the installation is the responsibility of the installer. The fixture presents risks of severe injury or death due to fire hazards, electric shock and falls.
- Warning! Risk Group 2 LED product according to EN 62471. Do not view the light output with optical instruments or any device that may concentrate the beam.
- WARRANTY: One year from date of purchase.

OPERATING DETERMINATIONS

If this equipment is operated in any other way, than those described in this manual, the product may suffer damage and the warranty becomes void. Incorrect operation may lead to danger e.g: short-circuit, burns and electric shocks etc.

Do not endanger your own safety and the safety of others!

Incorrect installation or use can cause serious damage to people and/or property.

Please note: These fixtures are intended for stage lighting and entertainment applications only, and are not intended for extended periods of use, including but not limited to house-light, industrial or architectural applications and should only be operated with short duty cycles.

Blitzer Impact 384 Strobe

The Blitzer Impact 384 is a creative multi-function strobe loaded with 256 SMD 5050 RGB LEDs divided into 32 individually controlled segments. In addition, there are 128 SMD 5730 white LEDs, divided into 16 segments, mounted horizontally across the centre of fixture creating a traditional strobe effect. Multiple chases across the RGB zones produce stunning effects when combined with the white LEDs, making it ideal for stages and events who want to produce eye-candy effects from a compact fixture.

- 256 tri-colour SMD 5050 LEDs (RGB) plus 128 white 5730 LEDs (CW)
- Viewing angle: 135°
- 10kHz refresh rate
- DMX channels: 6/9/64 or 112 selectable
- Static colour, auto, sound active and master/slave modes plus built-in programs
- 0-100% dimming
- Variable strobe
- Bracket allows for multiple rigging or floor standing applications
- Quick release omega clamp included
- 4 push button menu with LED display
- PowerCON input/output
- 3-Pin XLR input/output
- Fan cooled



Specifications	
Power consumption	93W
Power supply	100~240V, 50/60Hz
Fuse	F3A 250V
Dimensions	225 x 370 x 75mm
Weight	2kg
Order code	EQLED425

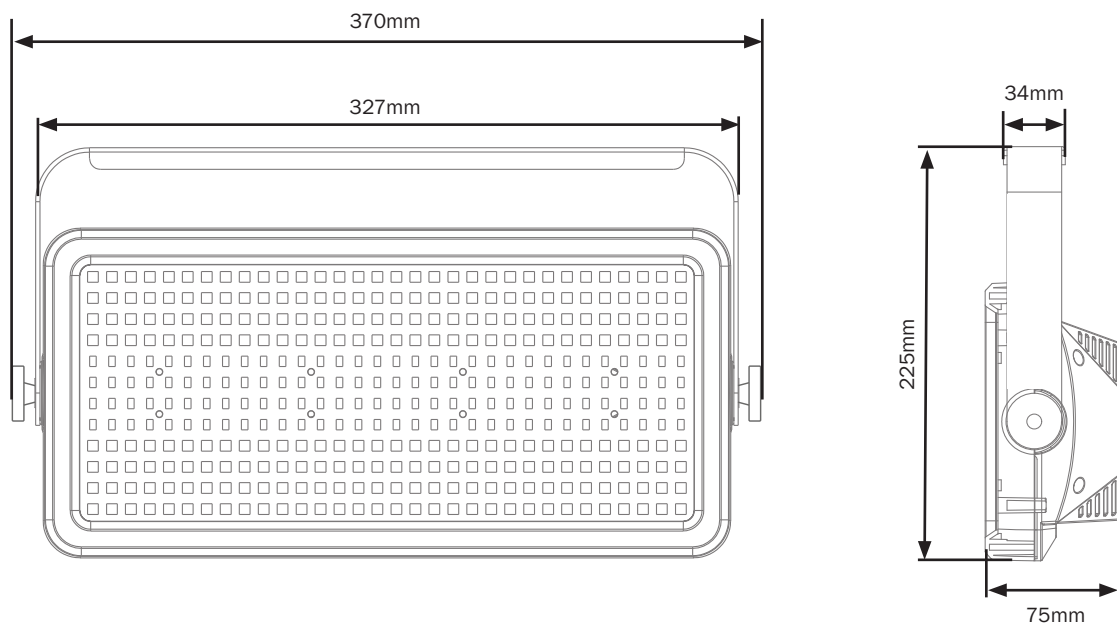

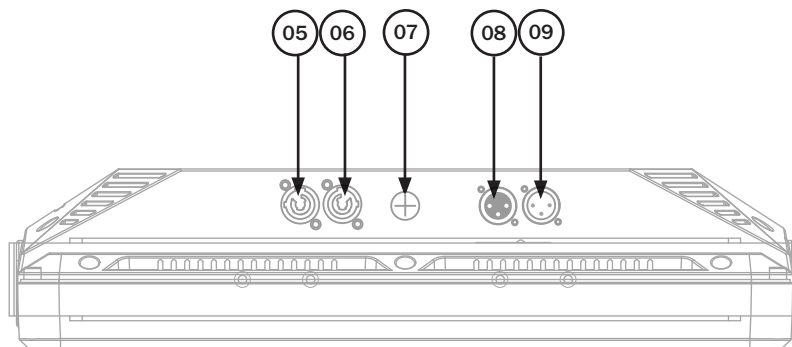
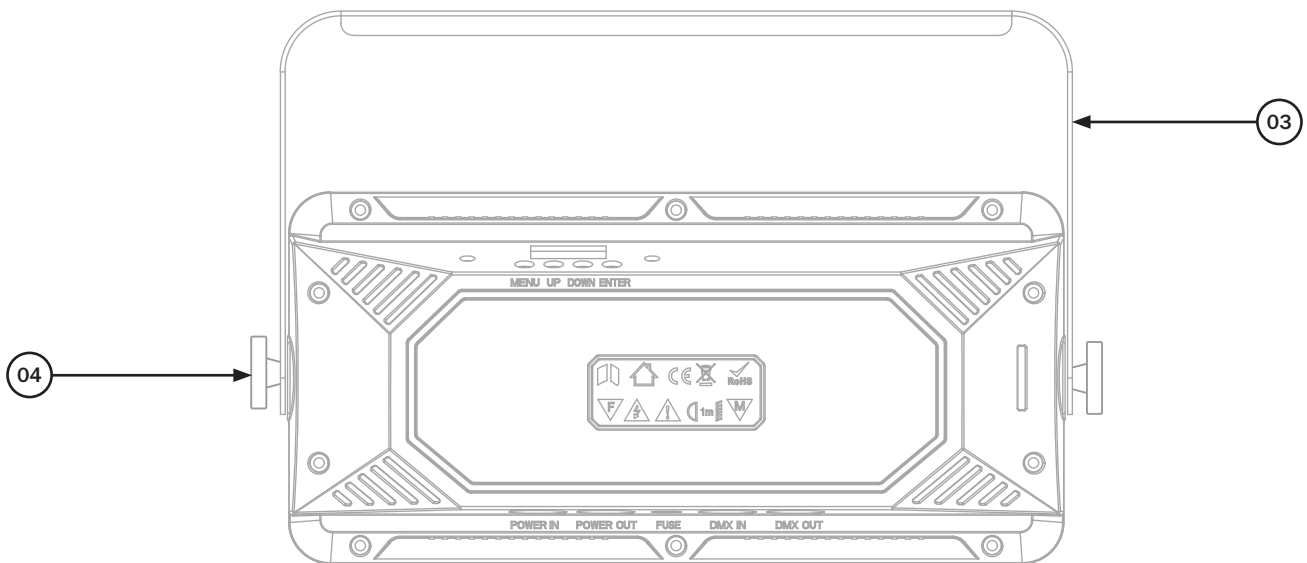
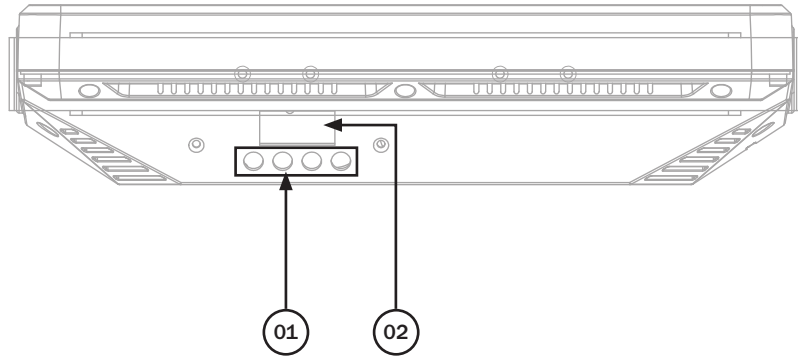

01 - Function buttons
02 - LED display
03 - Hanging bracket

04 - Bracket knobs
05 - PowerCON input
06 - PowerCON output

07 - Fuse F3A 250V
08 - 3-Pin XLR input
09 - 3-Pin XLR output

In the box:
1 x fixture with mounting bracket,
2 x adjustable knobs
1 x omega clamp
& 1 x power cable

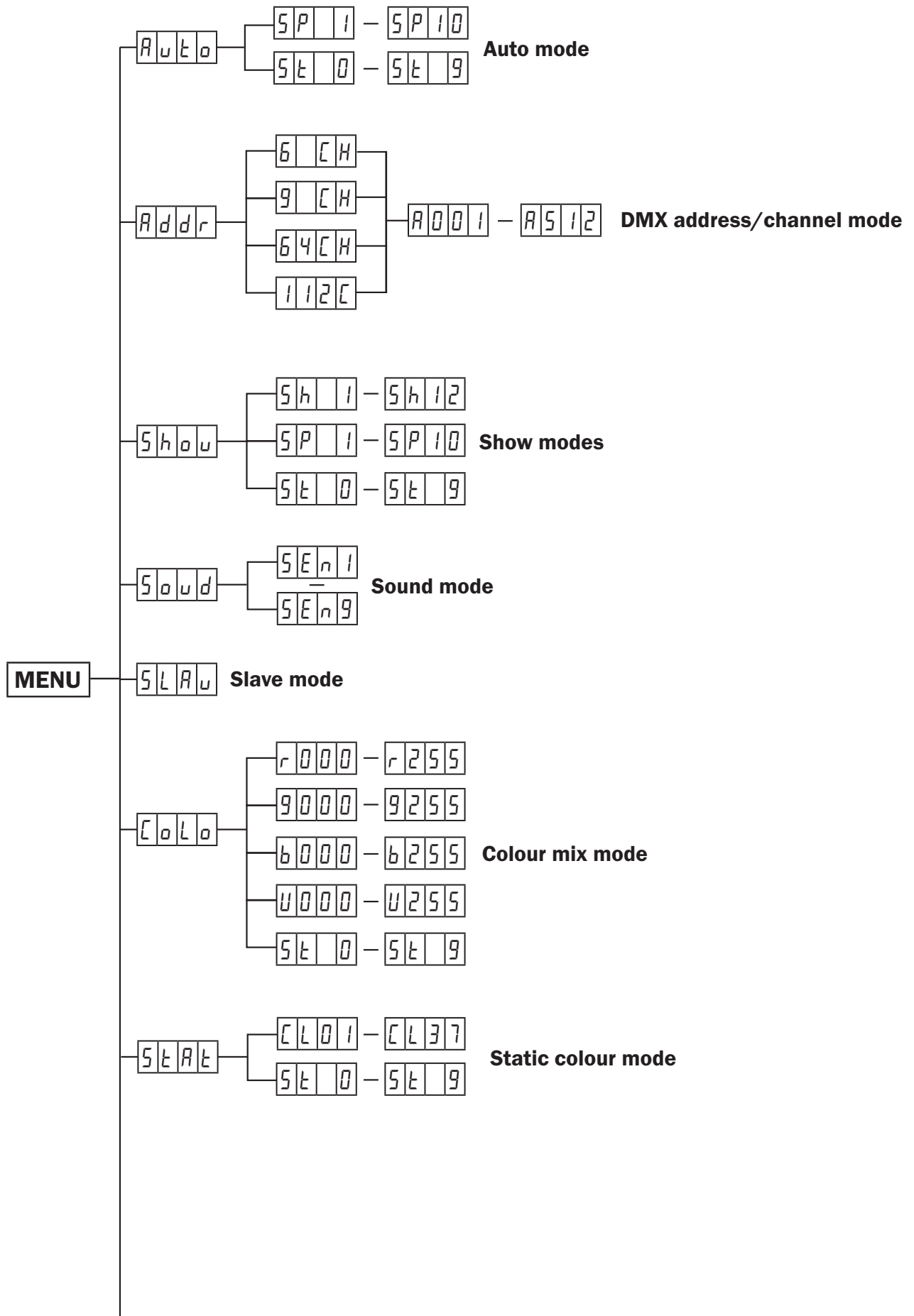

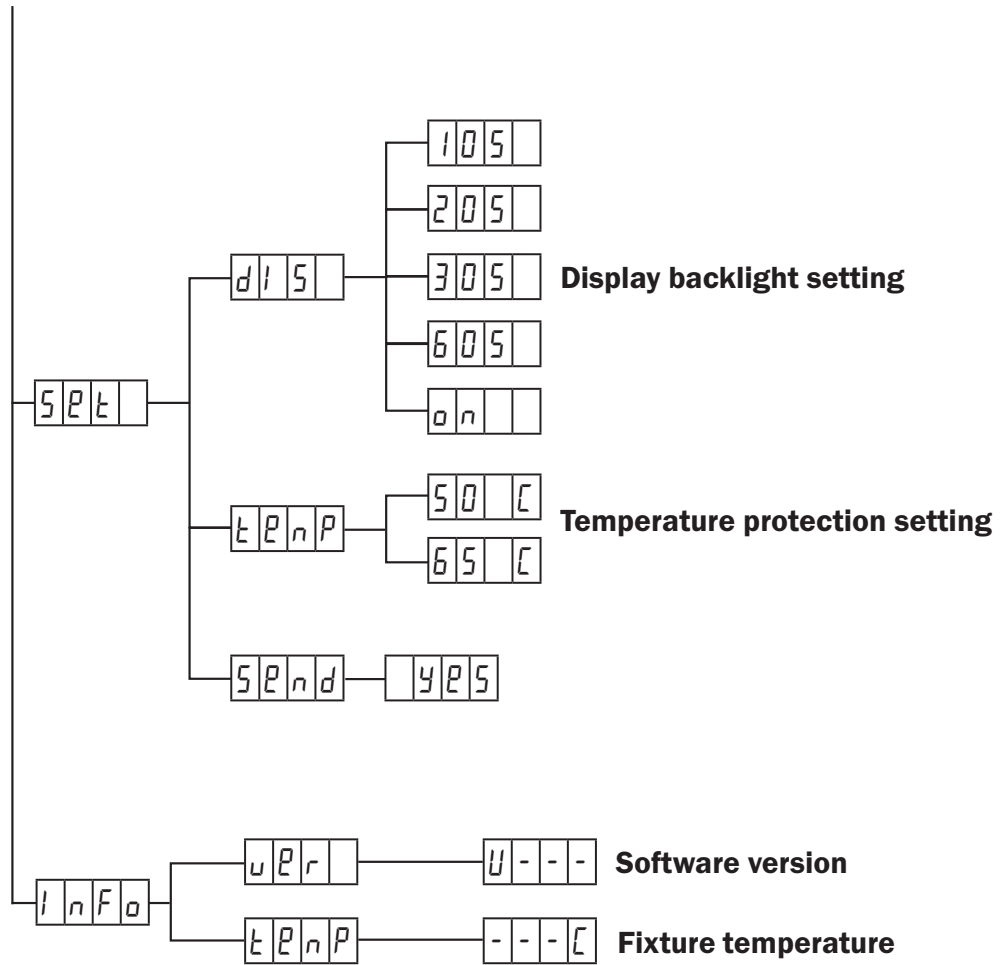

DMX mode:

To access the DMX address mode, press the “MENU” button to show *Addr* on the LED display. Press the “ENTER” button to confirm the setting. Now use the “UP” and “DOWN” buttons to choose one of the 6/9/64 or 112 DMX channel modes. Press the “ENTER” to confirm and use the “UP” and “DOWN” buttons to set the required DMX address.

To exit out of any of the above options, press the “MENU” button.

6 channel mode:

Channel	Value	Function
CH1	000-255	Master dimmer (0-100%)
CH2	000-009	No function
	010-255	Strobe (slow-fast)
CH3	000-255	Red dimmer (0-100%)
CH4	000-255	Green dimmer (0-100%)
CH5	000-255	Blue dimmer (0-100%)
CH6	000-255	White dimmer (0-100%)

9 channel mode:

Channel	Value	Function
CH1	000-255	Master dimmer (0-100%)
CH2	000-255	Red dimmer (0-100%)
CH3	000-255	Green dimmer (0-100%)
CH4	000-255	Blue dimmer (0-100%)
CH5	000-255	White dimmer (0-100%)
CH6	000-009	No function
	010-255	Strobe (slow-fast)
CH7	000-006	No Function
	007-013	Program 1
	014-020	Program 2
	021-027	Program 3
	028-034	Program 4
	035-041	Program 5
	042-048	Program 6
	049-055	Program 7
	056-062	Program 8
	063-069	Program 9
	070-076	Program 10
	077-083	Program 11
	084-090	Program 12
	091-097	Program 13
	098-104	Program 14
	105-111	Program 15
	112-118	Program 16
	119-125	Program 17
	126-132	Program 18
	133-139	Program 19
	140-146	Program 20
	147-153	Program 21
	154-160	Program 22
	161-167	Program 23
	168-174	Program 24
	175-181	Program 25
	182-188	Program 26
	189-195	Program 27
	196-202	Program 28
	203-209	Program 29
	210-216	Program 30
217-223	Program 31	

Channel	Value	Function
CH7 (cont.)	224-230	Program 32
	231-237	Program 33
	238-244	Program 34
	245-251	Auto
	252-255	Sound
CH8	000-006	No Function
	007-013	Program 1
	014-020	Program 2
	021-027	Program 3
	028-034	Program 4
	035-041	Program 5
	042-048	Program 6
	049-055	Program 7
	056-062	Program 8
	063-069	Program 9
	070-076	Program 10
	077-083	Program 11
	084-090	Program 12
	091-097	Program 13
	098-104	Program 14
	105-111	Program 15
	112-118	Program 16
	119-125	Program 17
	126-132	Program 18
	133-139	Program 19
	140-146	Program 20
	147-153	Program 21
	154-160	Program 22
	161-167	Program 23
	168-174	Program 24
	175-181	Program 25
	182-188	Program 26
	189-195	Program 27
	196-202	Program 28
	203-209	Program 29
	210-216	Program 30
	217-223	Program 31
	224-230	Program 32
231-255	Auto	
CH9	000-255	Speed (slow-fast)

64 channel mode:

Channel	Value	Function
CH1	000-255	RGB Red 1 & 17 (0-100%)
CH2	000-255	RGB Green 1 & 17 (0-100%)
CH3	000-255	RGB Blue 1 & 17 (0-100%)
CH4	000-255	RGB Red 2 & 18 (0-100%)
CH5	000-255	RGB Green 2 & 18 (0-100%)
CH6	000-255	RGB Blue 2 & 18 (0-100%)
CH7	000-255	RGB Red 3 & 19 (0-100%)
CH8	000-255	RGB Green 3 & 19 (0-100%)
CH9	000-255	RGB Blue 3 & 19 (0-100%)
CH10	000-255	RGB Red 4 & 20 (0-100%)
CH11	000-255	RGB Green 4 & 20 (0-100%)
CH12	000-255	RGB Blue 4 & 20 (0-100%)
CH13	000-255	RGB Red 5 & 21 (0-100%)
CH14	000-255	RGB Green 5 & 21 (0-100%)
CH15	000-255	RGB Blue 5 & 21 (0-100%)
CH16	000-255	RGB Red 6 & 22 (0-100%)
CH17	000-255	RGB Green 6 & 22 (0-100%)
CH18	000-255	RGB Blue 6 & 22 (0-100%)
CH19	000-255	RGB Red 7 & 23 (0-100%)
CH20	000-255	RGB Green 7 & 23 (0-100%)
CH21	000-255	RGB Blue 7 & 23 (0-100%)
CH22	000-255	RGB Red 8 & 24 (0-100%)
CH23	000-255	RGB Green 8 & 24 (0-100%)
CH24	000-255	RGB Blue 8 & 24 (0-100%)
CH25	000-255	RGB Red 9 & 25 (0-100%)
CH26	000-255	RGB Green 9 & 25 (0-100%)
CH27	000-255	RGB Blue 9 & 25 (0-100%)
CH28	000-255	RGB Red 10 & 26 (0-100%)
CH29	000-255	RGB Green 10 & 26 (0-100%)
CH30	000-255	RGB Blue 10 & 26 (0-100%)
CH31	000-255	RGB Red 11 & 27 (0-100%)
CH32	000-255	RGB Green 11 & 27 (0-100%)
CH33	000-255	RGB Blue 11 & 27 (0-100%)
CH34	000-255	RGB Red 12 & 28 (0-100%)
CH35	000-255	RGB Green 12 & 28 (0-100%)
CH36	000-255	RGB Blue 12 & 28 (0-100%)
CH37	000-255	RGB Red 13 & 29 (0-100%)
CH38	000-255	RGB Green 13 & 29 (0-100%)
CH39	000-255	RGB Blue 13 & 29 (0-100%)
CH40	000-255	RGB Red 14 & 30 (0-100%)

Channel	Value	Function
CH41	000-255	RGB Green 14 & 30 (0-100%)
CH42	000-255	RGB Blue 14 & 30 (0-100%)
CH43	000-255	RGB Red 15 & 31 (0-100%)
CH44	000-255	RGB Green 15 & 31 (0-100%)
CH45	000-255	RGB Blue 15 & 31 (0-100%)
CH46	000-255	RGB Red 16 & 32 (0-100%)
CH47	000-255	RGB Green 16 & 32 (0-100%)
CH48	000-255	RGB Blue 16 & 32 (0-100%)
CH49	000-255	White 1 (0-100%)
CH50	000-255	White 2 (0-100%)
CH51	000-255	White 3 (0-100%)
CH52	000-255	White 4 (0-100%)
CH53	000-255	White 5 (0-100%)
CH54	000-255	White 6 (0-100%)
CH55	000-255	White 7 (0-100%)
CH56	000-255	White 8 (0-100%)
CH57	000-255	White 9 (0-100%)
CH58	000-255	White 10 (0-100%)
CH59	000-255	White 11 (0-100%)
CH60	000-255	White 12 (0-100%)
CH61	000-255	White 13 (0-100%)
CH62	000-255	White 14 (0-100%)
CH63	000-255	White 15 (0-100%)
CH64	000-255	White 16 (0-100%)

112 channel mode:

Channel	Value	Function
CH1	000-255	RGB Red 1 (0-100%)
CH2	000-255	RGB Green 1 (0-100%)
CH3	000-255	RGB Blue 1 (0-100%)
CH4	000-255	RGB Red 2 (0-100%)
CH5	000-255	RGB Green 2 (0-100%)
CH6	000-255	RGB Blue 2 (0-100%)
CH7	000-255	RGB Red 3 (0-100%)
CH8	000-255	RGB Green 3 (0-100%)
CH9	000-255	RGB Blue 3 (0-100%)
CH10	000-255	RGB Red 4 (0-100%)
CH11	000-255	RGB Green 4 (0-100%)
CH12	000-255	RGB Blue 4 (0-100%)
CH13	000-255	RGB Red 5 (0-100%)
CH14	000-255	RGB Green 5 (0-100%)
CH15	000-255	RGB Blue 5 (0-100%)
CH16	000-255	RGB Red 6 (0-100%)
CH17	000-255	RGB Green 6 (0-100%)
CH18	000-255	RGB Blue 6 (0-100%)
CH19	000-255	RGB Red 7 (0-100%)
CH20	000-255	RGB Green 7 (0-100%)
CH21	000-255	RGB Blue 7 (0-100%)
CH22	000-255	RGB Red 8 (0-100%)
CH23	000-255	RGB Green 8 (0-100%)
CH24	000-255	RGB Blue 8 (0-100%)
CH25	000-255	RGB Red 9 (0-100%)
CH26	000-255	RGB Green 9 (0-100%)
CH27	000-255	RGB Blue 9 (0-100%)
CH28	000-255	RGB Red 10 (0-100%)
CH29	000-255	RGB Green 10 (0-100%)
CH30	000-255	RGB Blue 10 (0-100%)
CH31	000-255	RGB Red 11 (0-100%)
CH32	000-255	RGB Green 11 (0-100%)
CH33	000-255	RGB Blue 11 (0-100%)
CH34	000-255	RGB Red 12 (0-100%)
CH35	000-255	RGB Green 12 (0-100%)
CH36	000-255	RGB Blue 12 (0-100%)
CH37	000-255	RGB Red 13 (0-100%)
CH38	000-255	RGB Green 13 (0-100%)
CH39	000-255	RGB Blue 13 (0-100%)
CH40	000-255	RGB Red 14 (0-100%)

Channel	Value	Function
CH41	000-255	RGB Green 14 (0-100%)
CH42	000-255	RGB Blue 14 (0-100%)
CH43	000-255	RGB Red 15 (0-100%)
CH44	000-255	RGB Green 15 (0-100%)
CH45	000-255	RGB Blue 15(0-100%)
CH46	000-255	RGB Red 16 (0-100%)
CH47	000-255	RGB Green 16 (0-100%)
CH48	000-255	RGB Blue 16 (0-100%)
CH49	000-255	RGB Red 17 (0-100%)
CH50	000-255	RGB Green 17 (0-100%)
CH51	000-255	RGB Blue 17 (0-100%)
CH52	000-255	RGB Red 18 (0-100%)
CH53	000-255	RGB Green 18 (0-100%)
CH54	000-255	RGB Blue 18 (0-100%)
CH55	000-255	RGB Red 19 (0-100%)
CH56	000-255	RGB Green 19 (0-100%)
CH57	000-255	RGB Blue 19 (0-100%)
CH58	000-255	RGB Red 20 (0-100%)
CH59	000-255	RGB Green 20 (0-100%)
CH60	000-255	RGB Blue 20 (0-100%)
CH61	000-255	RGB Red 21 (0-100%)
CH62	000-255	RGB Green 21 (0-100%)
CH63	000-255	RGB Blue 21 (0-100%)
CH64	000-255	RGB Red 22 (0-100%)
CH65	000-255	RGB Green 22 (0-100%)
CH66	000-255	RGB Blue 22 (0-100%)
CH67	000-255	RGB Red 23 (0-100%)
CH68	000-255	RGB Green 23 (0-100%)
CH69	000-255	RGB Blue 23 (0-100%)
CH70	000-255	RGB Red 24 (0-100%)
CH71	000-255	RGB Green 24(0-100%)
CH72	000-255	RGB Blue 24 (0-100%)
CH73	000-255	RGB Red 25 (0-100%)
CH74	000-255	RGB Green 25 (0-100%)
CH75	000-255	RGB Blue 25 (0-100%)
CH76	000-255	RGB Red 26 (0-100%)
CH77	000-255	RGB Green 26 (0-100%)
CH78	000-255	RGB Blue 26 (0-100%)
CH79	000-255	RGB Red 27 (0-100%)
CH80	000-255	RGB Green 27 (0-100%)

112 channel mode (cont):

Channel	Value	Function
CH81	000-255	RGB Blue 27 (0-100%)
CH82	000-255	RGB Red 28 (0-100%)
CH83	000-255	RGB Green 28 (0-100%)
CH84	000-255	RGB Blue 28 (0-100%)
CH85	000-255	RGB Red 29 (0-100%)
CH86	000-255	RGB Green 29 (0-100%)
CH87	000-255	RGB Blue 29(0-100%)
CH88	000-255	RGB Red 30 (0-100%)
CH89	000-255	RGB Green 30 (0-100%)
CH90	000-255	RGB Blue 30 (0-100%)
CH91	000-255	RGB Red 31 (0-100%)
CH92	000-255	RGB Green 31 (0-100%)
CH93	000-255	RGB Blue 31 (0-100%)
CH94	000-255	RGB Red 32 (0-100%)
CH95	000-255	RGB Green 32 (0-100%)
CH96	000-255	RGB Blue 32 (0-100%)
CH97	000-255	White 1 (0-100%)
CH98	000-255	White 2 (0-100%)
CH99	000-255	White 3 (0-100%)
CH100	000-255	White 4 (0-100%)
CH101	000-255	White 5 (0-100%)
CH102	000-255	White 6 (0-100%)
CH103	000-255	White 7 (0-100%)
CH104	000-255	White 8 (0-100%)
CH105	000-255	White 9 (0-100%)
CH106	000-255	White 10 (0-100%)
CH107	000-255	White 11 (0-100%)
CH108	000-255	White 12 (0-100%)
CH109	000-255	White 13 (0-100%)
CH110	000-255	White 14 (0-100%)
CH111	000-255	White 15 (0-100%)
CH112	000-255	White 16 (0-100%)

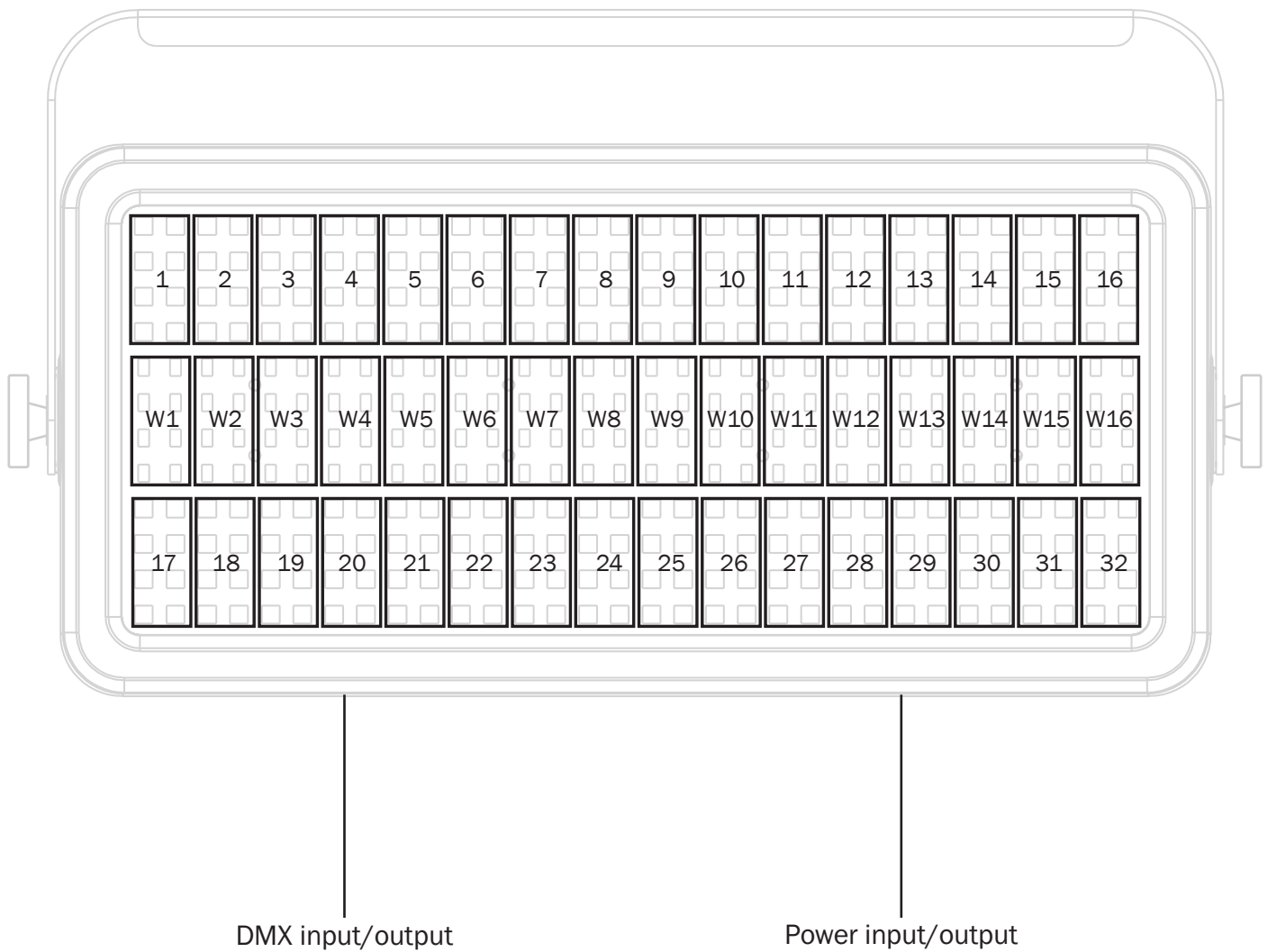

Auto mode:

To access auto mode, press the “MENU” button to show *AUTO* on the LED display. Now press the “ENTER” button and use the “UP” and “DOWN” buttons to select the speed between *SP 1 ~ SP 10*. Press the “ENTER” button to confirm the setting and use the “UP” and “DOWN” buttons to select the flash speed between *St 0 ~ St 9*.

Press the “ENTER” button to confirm the setting.

Show modes (built-in programs):

To access the show modes (built-in programs), press the “MENU” button to show *Show* on the LED display. Now press the “ENTER” button and use the “UP” and “DOWN” buttons to choose the required program *Sh 1 ~ Sh 12*. Press the “ENTER” button and use the “UP” and “DOWN” buttons to select the speed between *SP 1 ~ SP 10*. Press the “ENTER” button to confirm the setting and use the “UP” and “DOWN” buttons to select the flash speed between *St 0 ~ St 9*.

Press the “ENTER” button to confirm the setting.

To exit out of any of the above options, press the “MENU” button.

Sound modes:

To access the sound modes (built-in programs), press the “MENU” button to show *Sound* on the LED display. Press the “ENTER” button and use the “UP” and “DOWN” buttons to select the sound sensitivity between *SEn 1 ~ SEn 9*. Press the “ENTER” button to confirm the setting.

To exit out of any of the above options, press the “MENU” button.

Master/slave mode:

The default setting for this fixture is master. To set the master unit, select from one of the auto, show, sound, colour mix or static colour modes.

To set the slave unit, press the “MENU” button to show *SLAVE* on the LED display.

The unit is now in slave mode. To exit out of any of the above options, press the “MENU” button.

Please ensure that all slave units are set to the same DMX channel mode as the master unit.

Colour mix mode:

To access the static colour mode press “MENU” until *COLO* shows on the LED display.

Now press the “ENTER” button and use the “UP” and “DOWN” buttons to select the brightness between *r.000 ~ r.255*. Press the “ENTER” button and repeat for green (*g*) blue (*b*) and white (*W*).

Press the “ENTER” button to confirm the setting and use the “UP” and “DOWN” buttons to select the flash speed between *St 0 ~ St 9*.

Value: 000 - 255 (000 = low brightness, 255 = high brightness)

To exit out of any of the above options, press the “MENU” button.

Menu	Colour Values		
	R	G	B
CL01	255	000	000
CL02	255	050	000
CL03	255	100	000
CL04	255	150	000
CL05	255	190	000
CL06	255	255	000
CL07	255	255	000
CL08	255	255	000
CL09	190	255	000
CL10	150	255	000
CL11	100	255	000
CL12	050	255	000

Menu	Colour Values		
	R	G	B
CL13	000	255	000
CL14	000	255	050
CL15	000	255	100
CL16	000	255	150
CL17	000	255	190
CL18	000	255	255
CL19	000	255	255
CL20	000	255	255
CL21	000	190	255
CL22	000	150	255
CL23	000	100	255
CL24	000	050	255

Menu	Colour Values		
	R	G	B
CL25	000	000	255
CL26	050	000	255
CL27	100	000	255
CL28	150	000	255
CL29	190	000	255
CL30	255	000	255
CL31	255	000	255
CL32	255	000	255
CL33	255	000	190
CL34	255	000	150
CL35	255	000	100
CL36	255	000	050
CL37	255	255	255

Static colour mode:

To access the static colour mode, press the “MENU” button to show *StAt* on the LED display. Now press the “ENTER” button and use the “UP” and “DOWN” buttons to choose the required colour between *CL01 ~ CL37*. Press the “ENTER” button to confirm the setting. Then use the “UP” and “DOWN” buttons to choose the required strobe setting between *St 0 ~ St 9*.

Press the “ENTER” button to confirm the setting.

To exit out of any of the above options, press the “MENU” button.

Display backlight setting:

To access the display backlight setting, press the “MENU” button to show *StEt* on the LED display. Now press the “ENTER” button and use the “UP” and “DOWN” buttons to select *dl 5*. Press the “ENTER” button and use the “UP” and “DOWN” buttons to select between *10 5* (10 seconds), *20 5* (20 seconds), *30 5* (30 seconds), *60 5* (60 seconds) or *on* (constantly on).

Press the “ENTER” button to confirm the setting.

To exit out of any of the above options, press the “MENU” button.

Temperature setting:

To access the temperature protection setting, press the “MENU” button to show *StEt* on the LED display. Now press the “ENTER” button and use the “UP” and “DOWN” buttons to select *tPnP*. Press the “ENTER” button to select between *50 C - 65 C*. Once the fixture reaches the temperature set the output will be reduced.

Send setting:

To send DMX channel mode to all fixtures, press the “MENU” button to show *SEt* on the LED display. Now press the “ENTER” button and use the “UP” and “DOWN” buttons to select *Send*. Press the “ENTER” button to select *YES*.

Software version:

To view the fixtures software version, press the “MENU” button to show *Info* on the LED display. Now press the “ENTER” button to show *Ver*, press the “ENTER” button again and the software version will be displayed. To exit out of any of the above options, press the “MENU” button.

Please ensure that all slave units are set to the same DMX channel mode as the master unit.

Fixture temperature:

To access the fixture temperature press the “MENU” button to show *Info* on the LED display. Now press the “ENTER” button and use the “UP” and “DOWN” buttons to select *Temp*. Press the “ENTER” button to display the temperature.

Setting the DMX address:

The DMX mode enables the use of a universal DMX controller. Each fixture requires a “start address” from 1- 512. A fixture requiring one or more channels for control begins to read the data on the channel indicated by the start address. For example, a fixture that occupies or uses 7 channels of DMX and was addressed to start on DMX channel 100, would read data from channels: 100, 101, 102, 103, 104, 105 and 106. Choose a start address so that the channels used do not overlap. E.g. the next unit in the chain starts at 107.

DMX 512:

DMX (Digital Multiplex) is a universal protocol used as a form of communication between intelligent fixtures and controllers. A DMX controller sends DMX data instructions from the controller to the fixture. DMX data is sent as serial data that travels from fixture to fixture via the DATA “IN” and DATA “OUT” XLR terminals located on all DMX fixtures (most controllers only have a data “out” terminal).

DMX linking:

DMX is a language allowing all makes and models of different manufactures to be linked together and operate from a single controller, as long as all fixtures and the controller are DMX compliant. To ensure proper DMX data transmission, when using several DMX fixtures try to use the shortest cable path possible. The order in which fixtures are connected in a DMX line does not influence the DMX addressing. For example; a fixture assigned to a DMX address of 1 may be placed anywhere in a DMX line, at the beginning, at the end, or anywhere in the middle. When a fixture is assigned a DMX address of 1, the DMX controller knows to send DATA assigned to address 1 to that unit, no matter where it is located in the DMX chain.

DATA cable (DMX cable) requirements (for DMX operation):

This fixture can be controlled via DMX-512 protocol. The DMX address is set on the back of the unit. Your unit requires either a standard 3-pin or 5-pin XLR connector for data input/output, see images below.

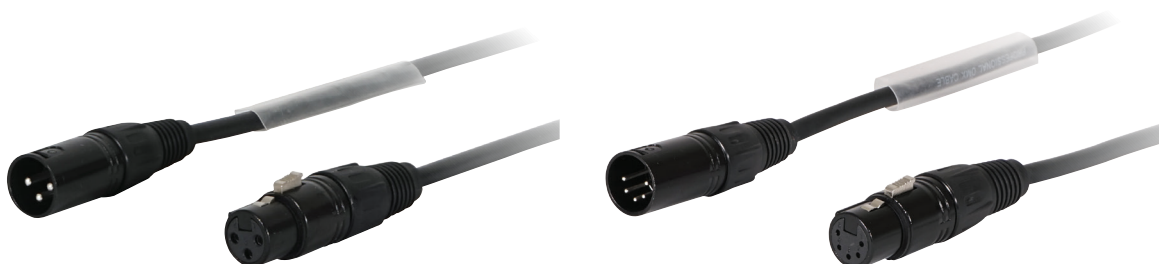

Further DMX cables can be purchased from all good sound and lighting suppliers or Prolight Concepts dealers.

Please quote:	3-Pin:	CABL10 - 2m	CABL11 - 5m	CABL12 - 10m
	5-Pin:	CABL185 - 2m	CABL187 - 5m	CABL188 - 10m

Also remember that DMX cable must be daisy chained and cannot be split.

Notice:

Be sure to follow the diagrams below when making your own cables. Do not connect the cables shield conductor to the ground lug or allow the shield conductor to come in contact with the XLRs outer casing. Grounding the shield could cause a short circuit and erratic behaviour.

Pin Configuration	
3-Pin	5-Pin
	Pin 1 - Ground
	Pin 2 - Negative
	Pin 3 - Positive
-	Pin 4 - N/C
-	Pin 5 - N/C

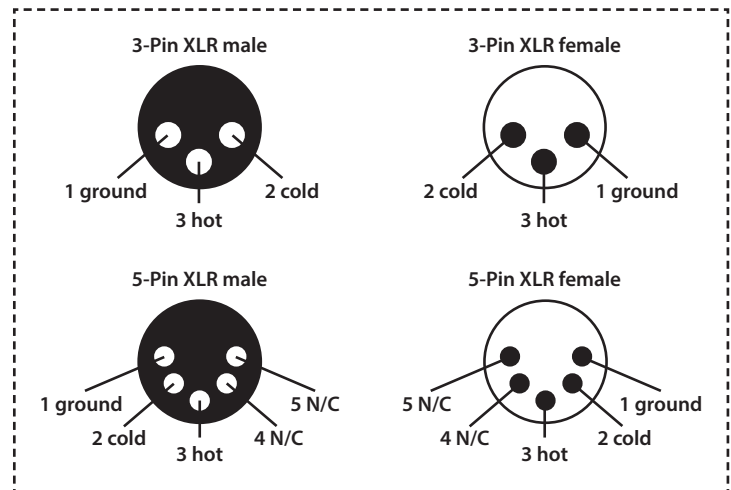
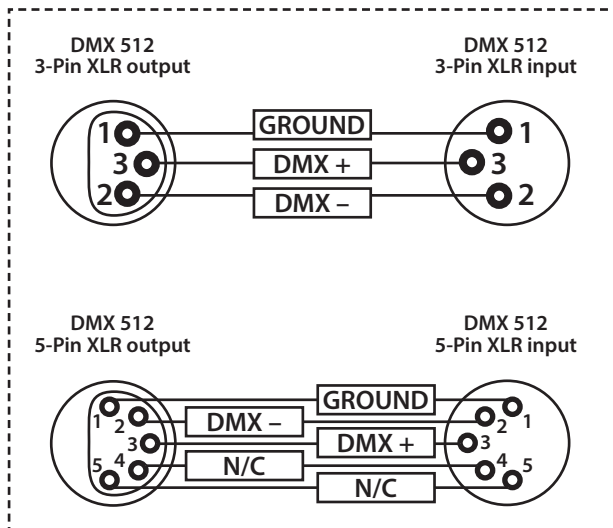

Line termination:

When longer runs of cable are used, you may need to use a terminator on the last unit to avoid erratic behaviour.

Using a cable terminator will decrease the possibilities of erratic behaviour.

(3-pin - Order ref: CABL90,
5-pin - Order ref: CABL89)

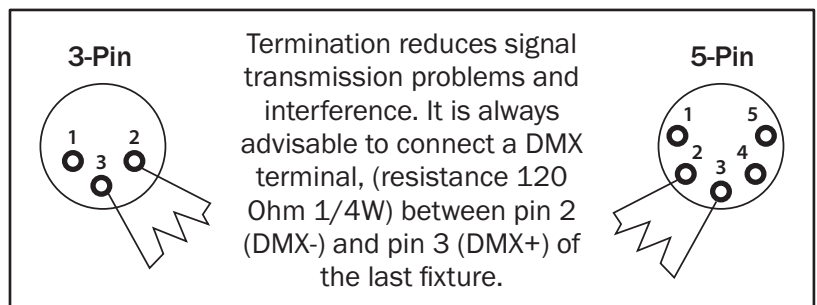

5-pin XLR DMX connectors:

Some manufactures use 5-pin XLR connectors for data transmission in place of 3-pin. 5-pin XLR fixtures may be implemented in a 3-pin XLR DMX line. When inserting standard 5-pin XLR connectors in to a 3-pin line a cable adaptor must be used. The diagram below details the correct cable conversion.

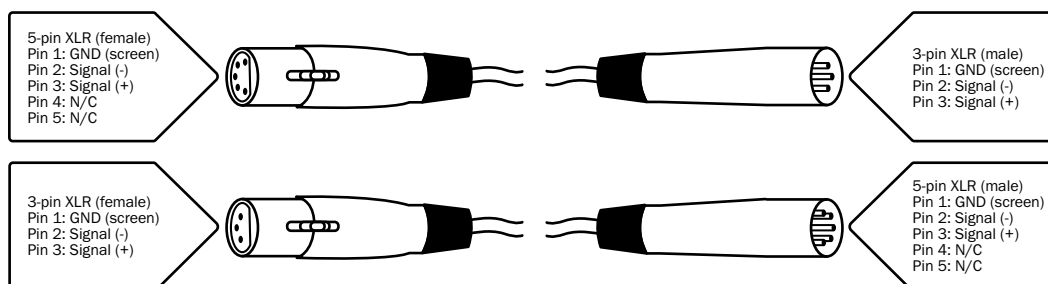

Power linking:

This fixture provides power linking via the power output on the rear allowing multiple units to be connected together. The maximum number of fixtures that can be connected is 24 fixtures @ 240V or 12 fixtures @ 120V (including the first fixture). After the maximum number of fixtures are connected a new power run will need to be started.

Please note: Caution should be used when power linking other fixtures to the Blitzer Impact 384 Strobe as the power consumption of other fixtures will vary. Fixtures fitted with lamps often require 2/3 times more current on startup, these may require their own power source.

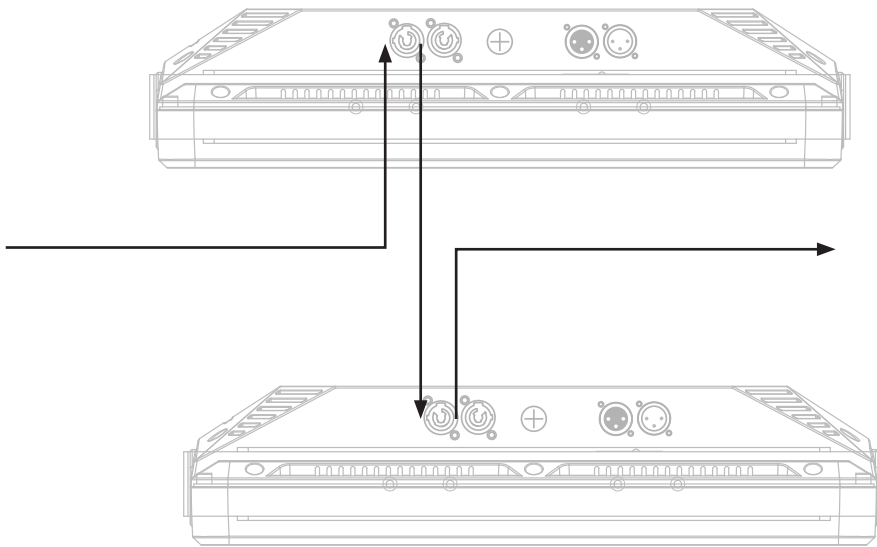



Correct Disposal of this Product (Waste Electrical & Electronic Equipment)

**(Applicable in the European Union and other European countries
with separate collection systems)**

This marking shown on the product or its literature, indicates that it should not be disposed of with other household wastes at the end of its working life. To prevent possible harm to the environment or human health from uncontrolled waste disposal, please separate this from other types of wastes and recycle it responsibly to promote the sustainable reuse of material resources.

Household users should contact either the retailer where they purchased this product, or their local government office, for details of where and how they can take this item for environmentally safe recycling.

Business users should contact their supplier and check the terms and conditions of the purchase contract. This product should not be mixed with other commercial wastes for disposal.



EQUINOX